

Block diagram EM11_10 (ver.0.0 ed.2)

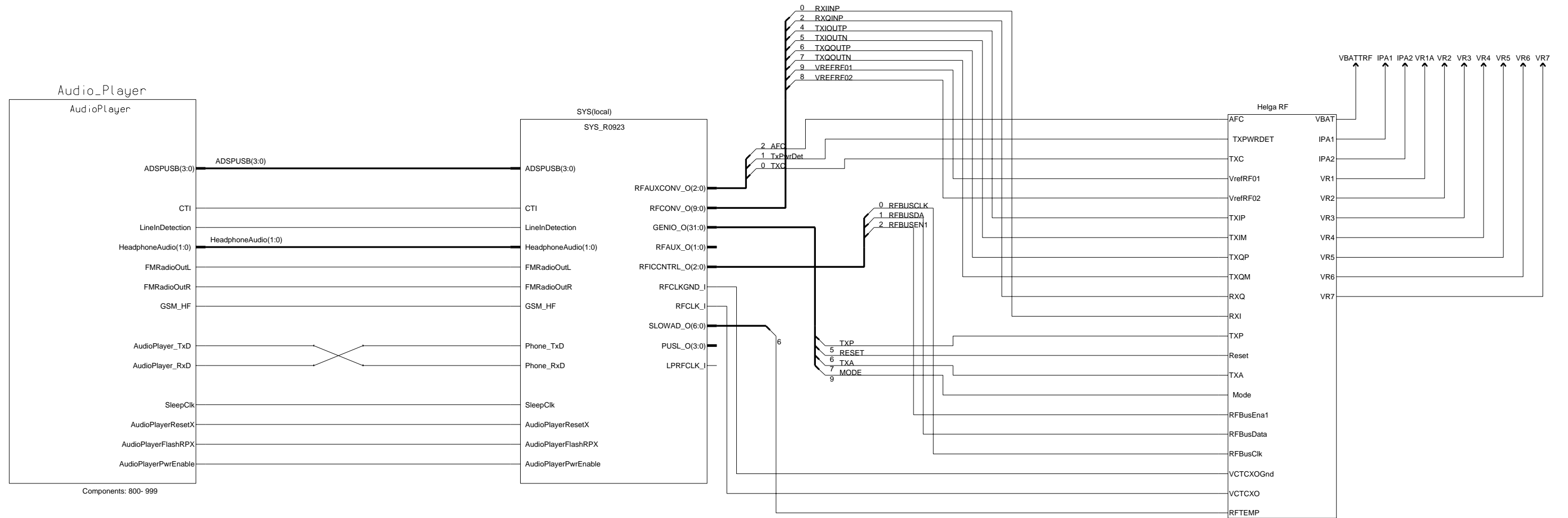

Block diagram baseband (v.0.0 ed 2)

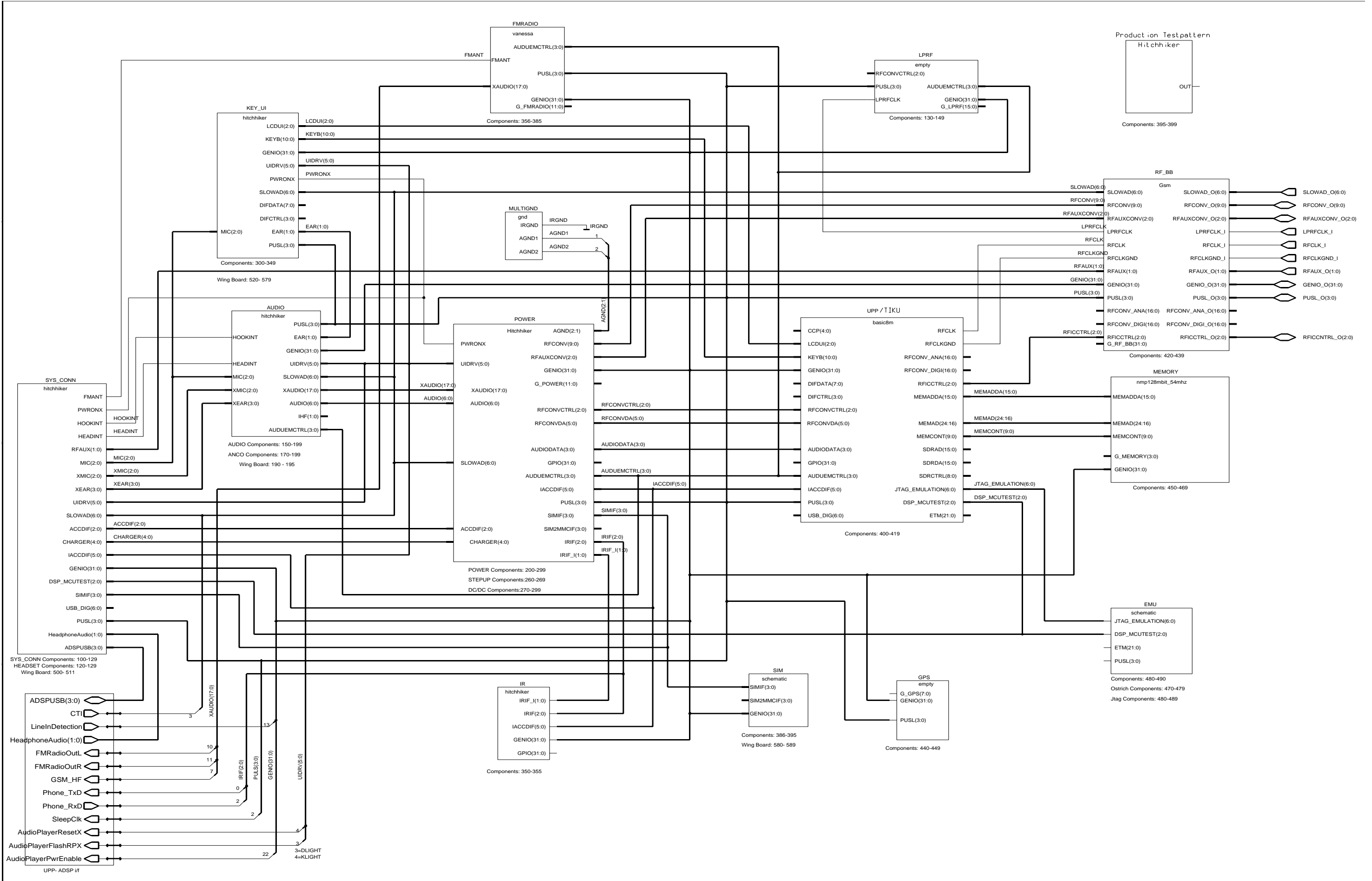

System Connector (ver. 0 ed. 2)

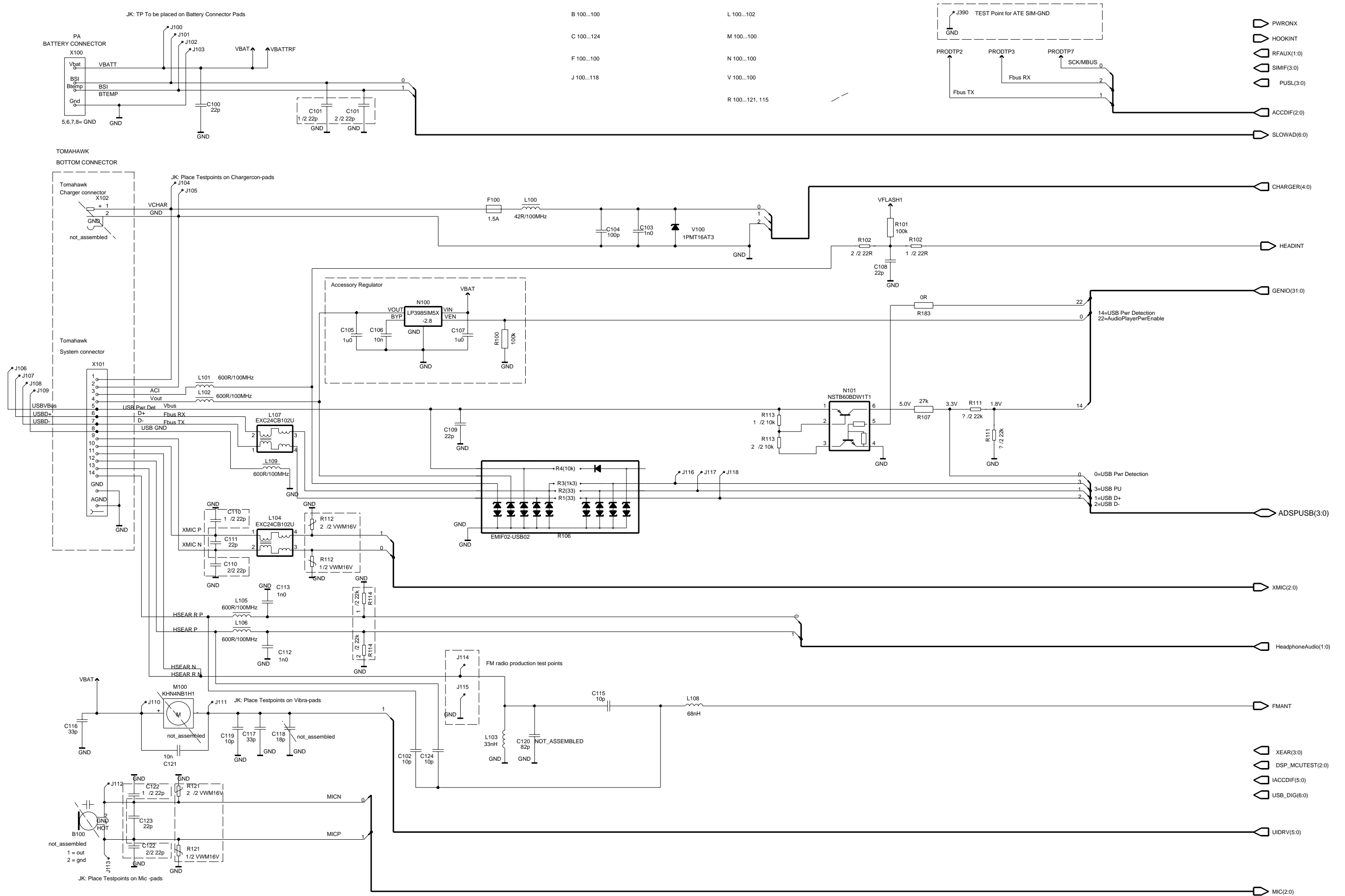

Key user Interface (ver.0.0 ed. 2)

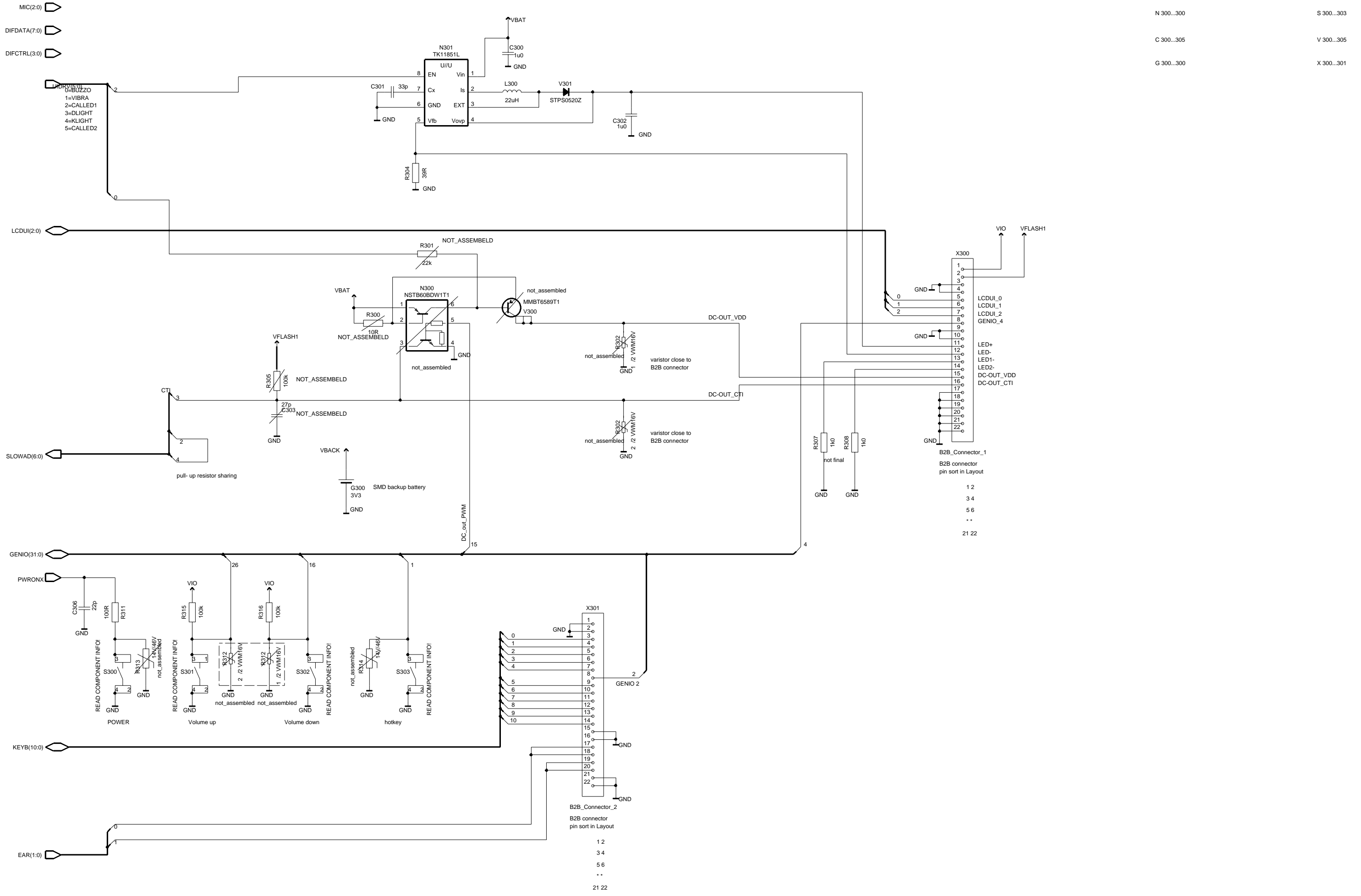

N 300...300	S 300...303
C 300...305	V 300...305
G 300...300	X 300...301

Audio (ver. 0.0 ed. 2)

R 150...155

C 150...160

Varistor arrays have reliability issues

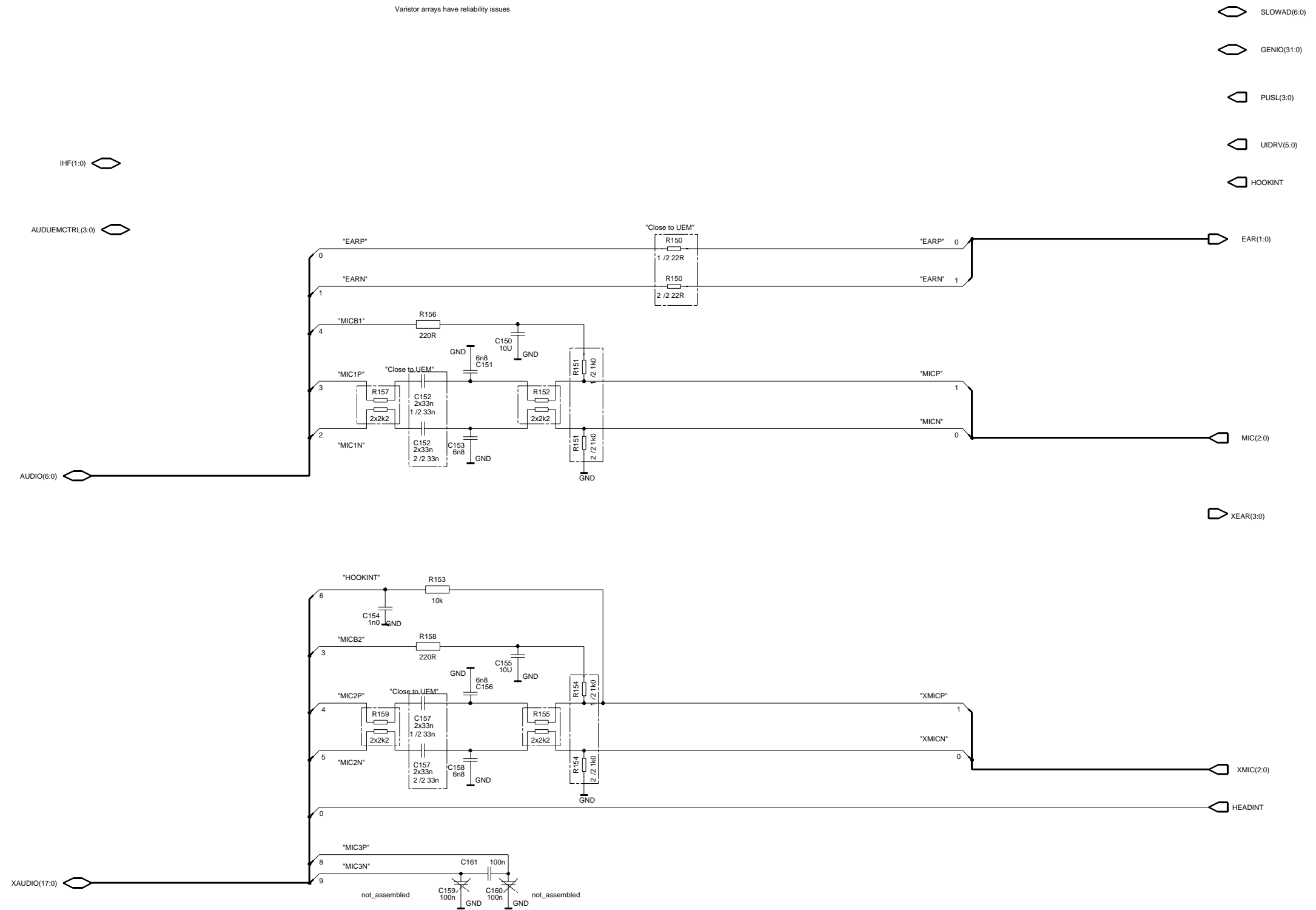

Audio player block diagram (ver.0.0 ed. 2)

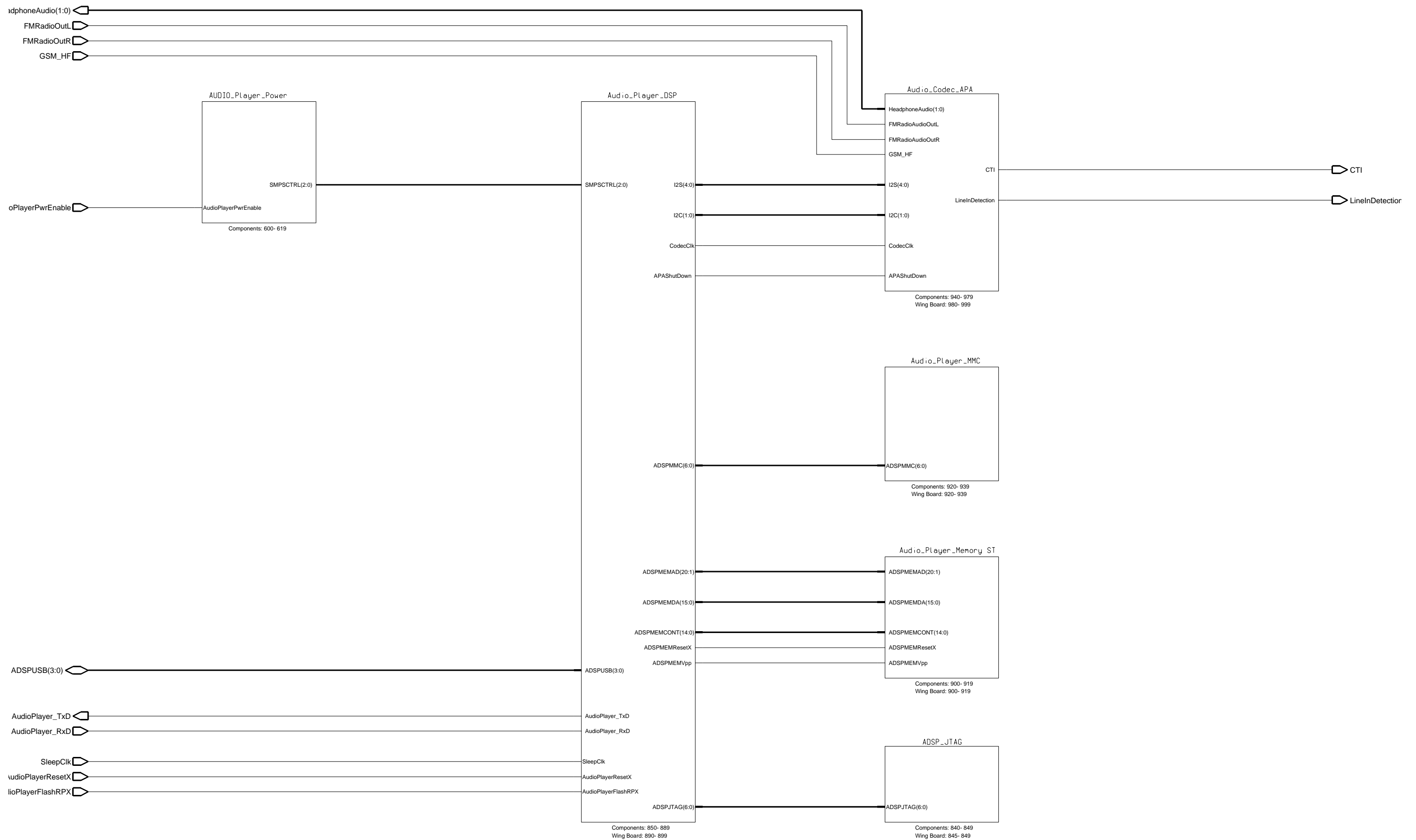

Audio Power (ver.0 ed. 2)

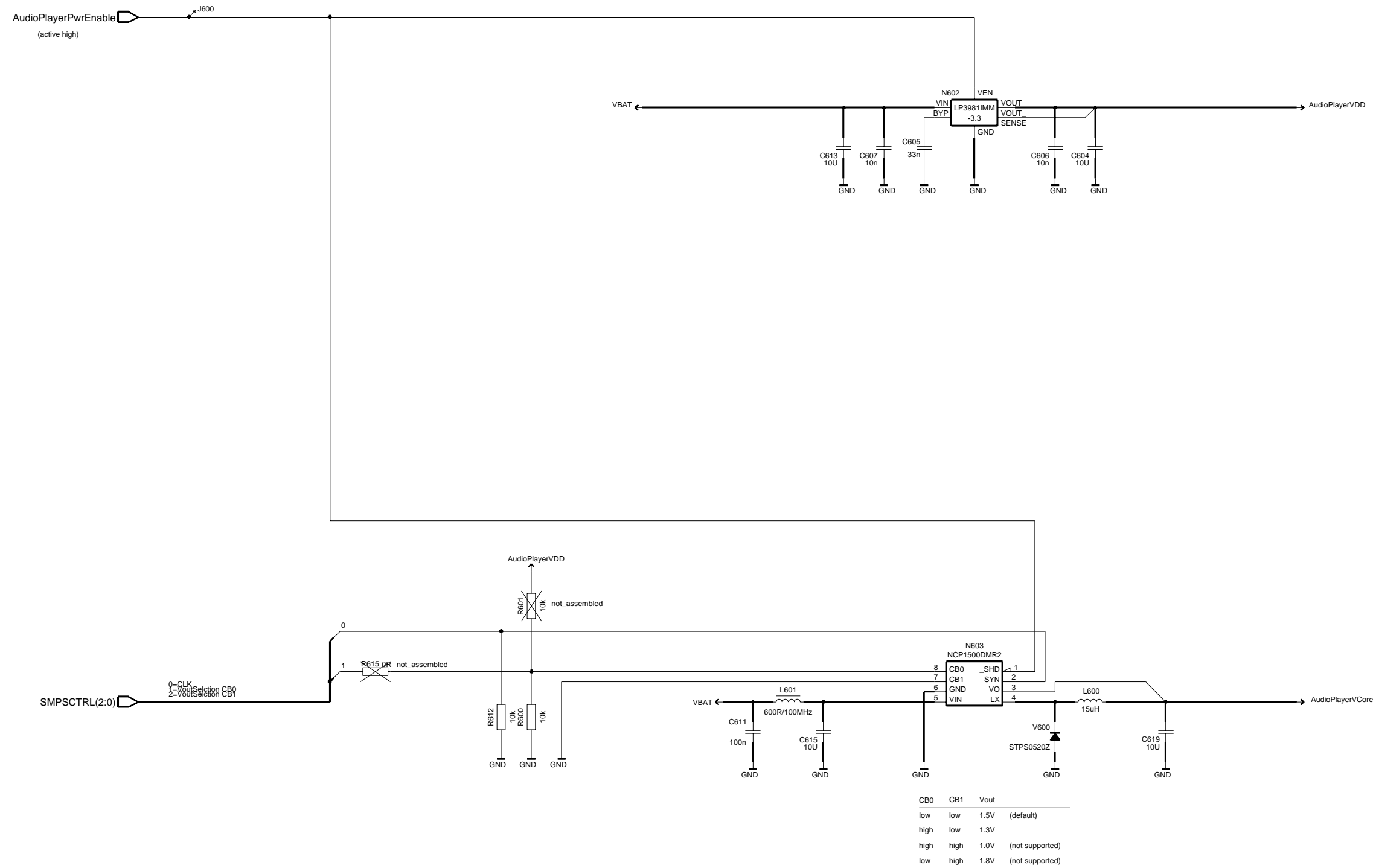

Audio DSP (ed. 0.0 ed.2)

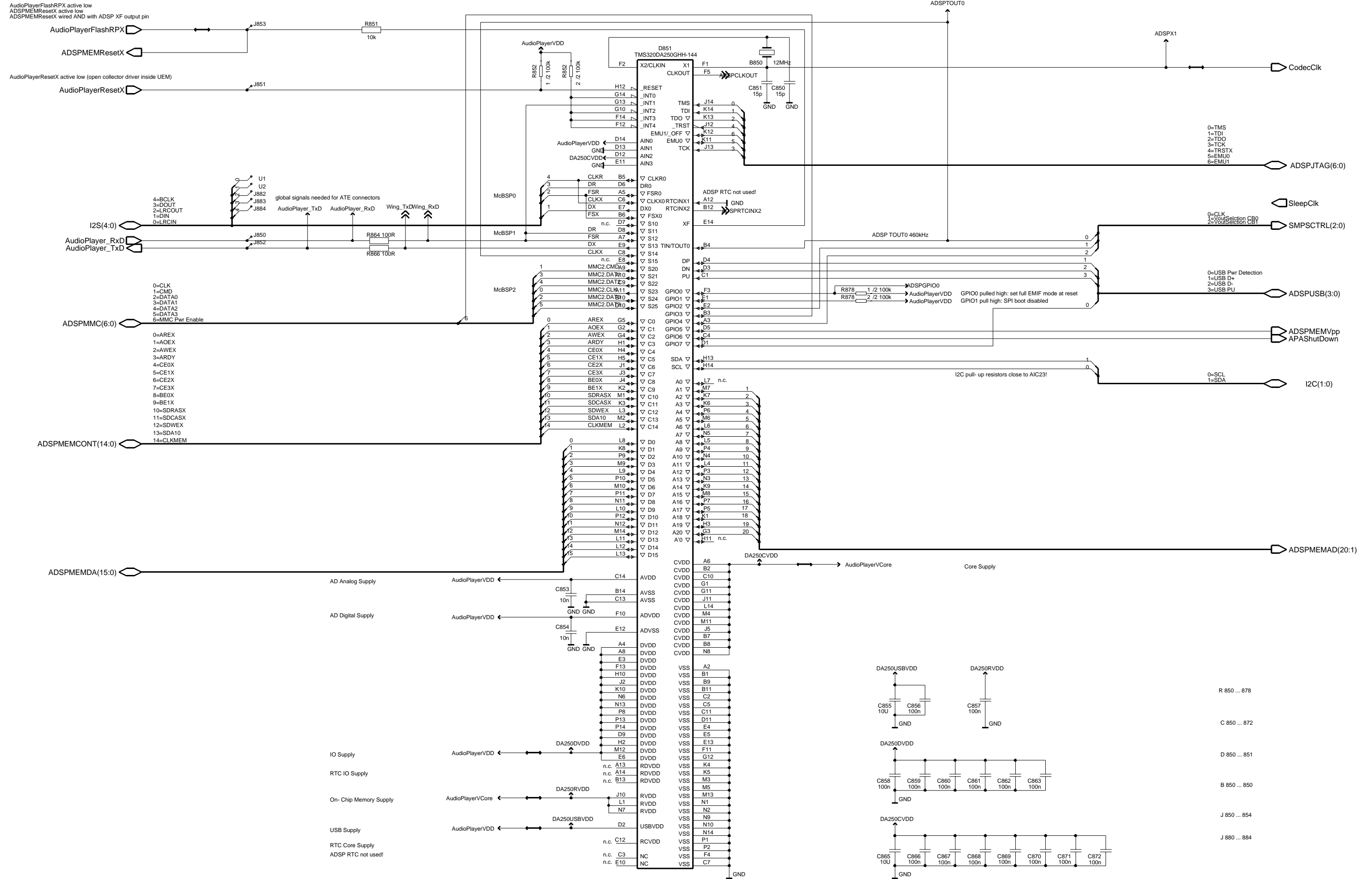

Memory ST (ver. 0 ed.2)

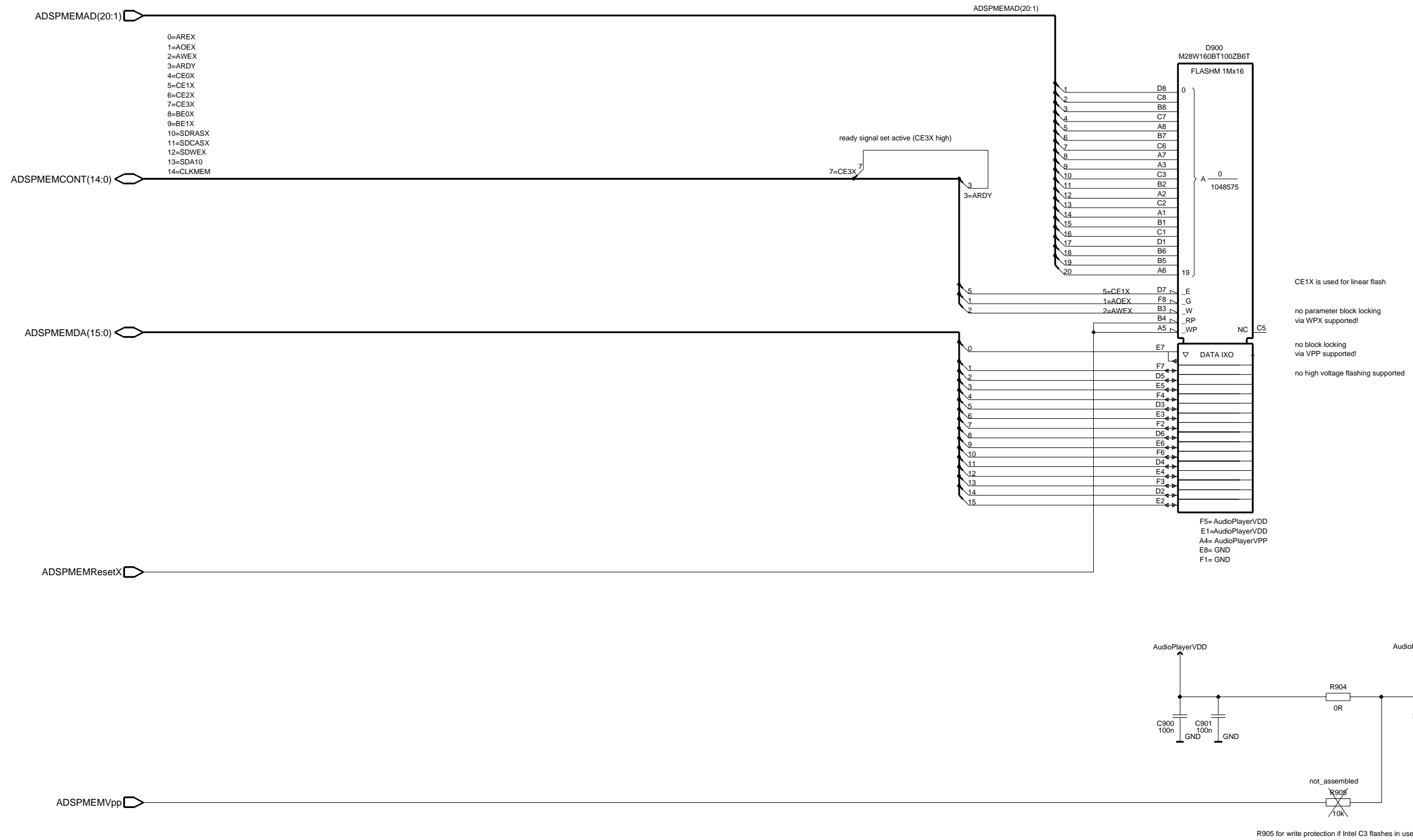

Audio Codec (ed. 0 ver. 2)

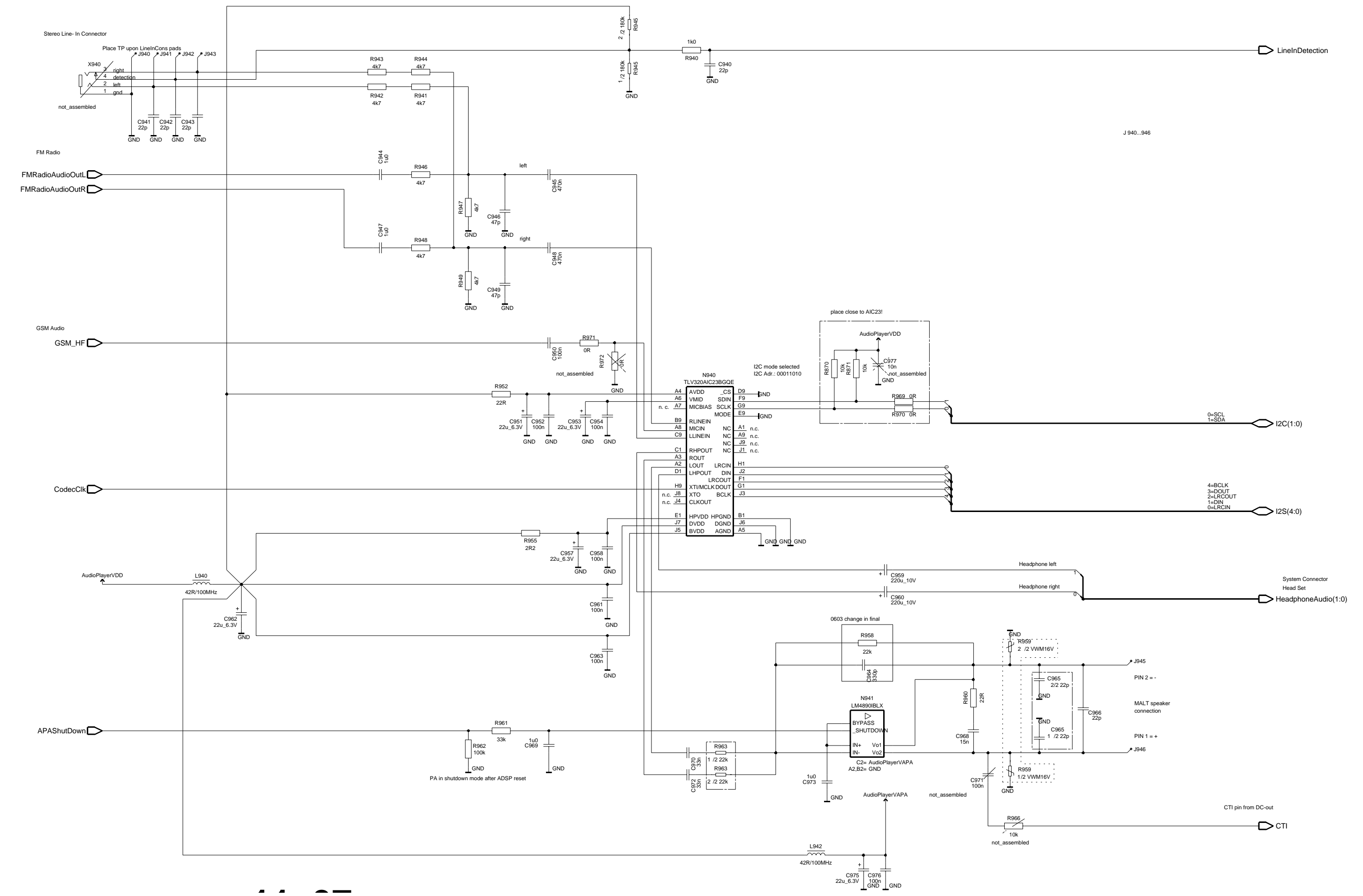

MMC (v.0 ed. 2)

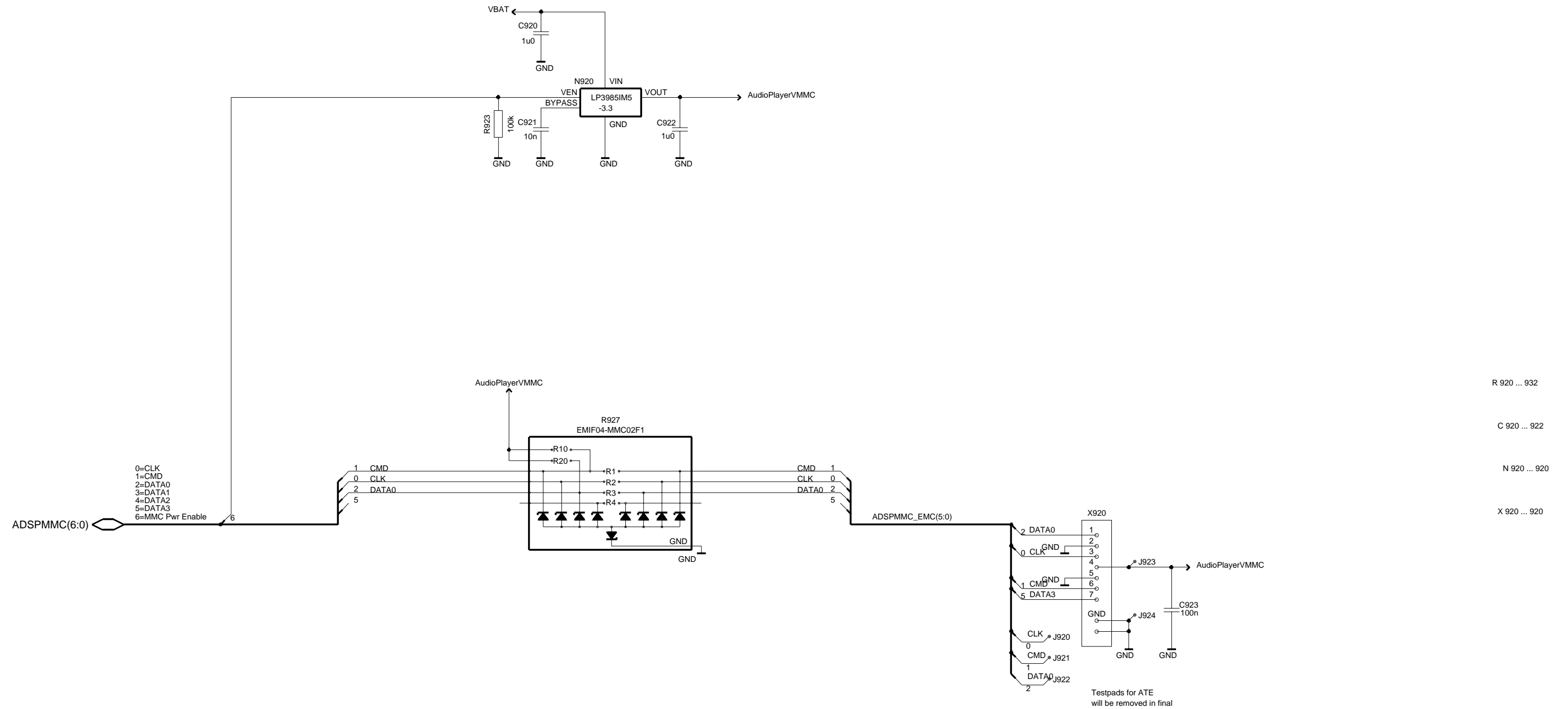

JTAG interface (ed. 0 ver. 2)

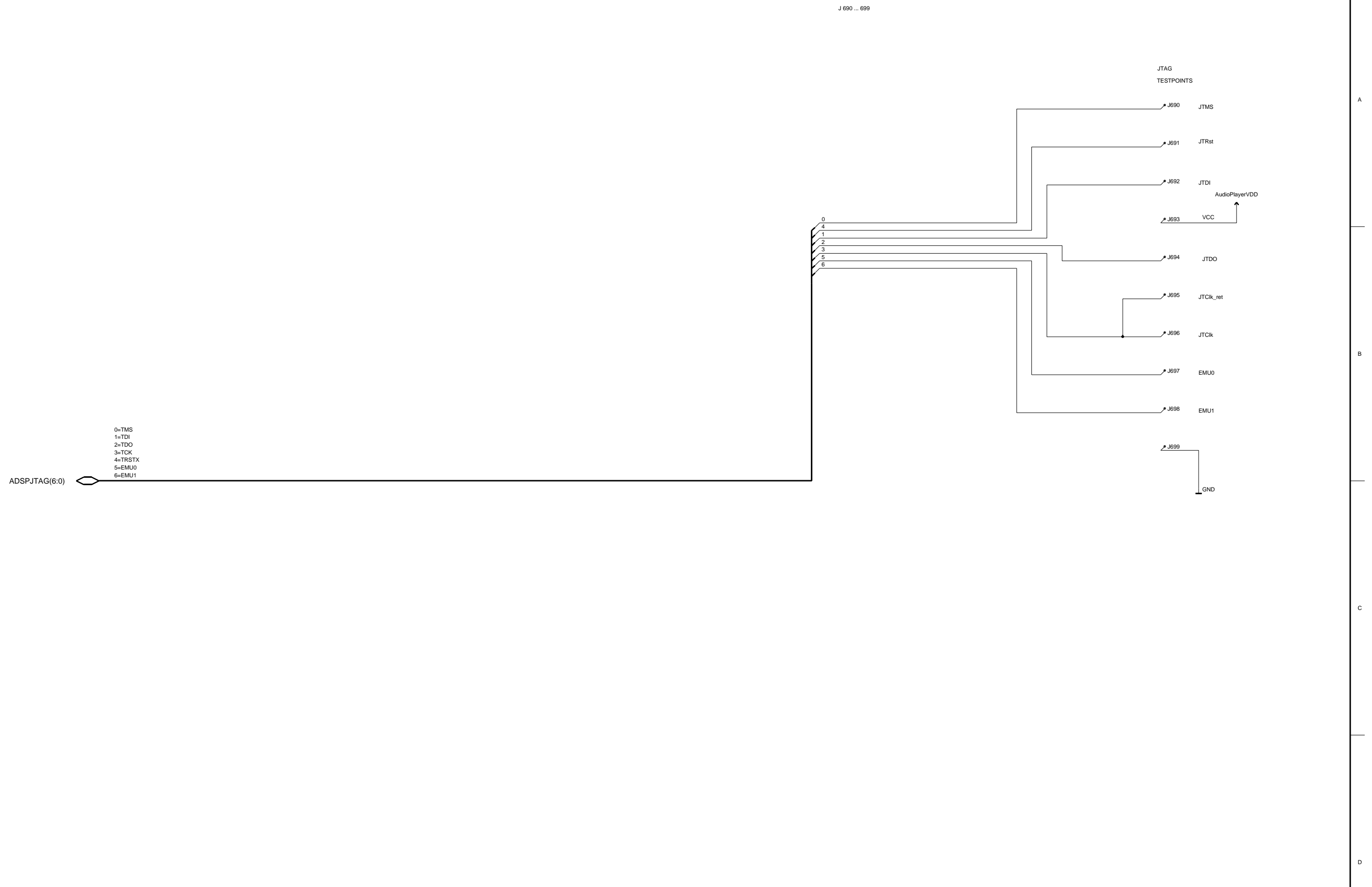

RF block diagram (ed.0.0 ver. 2)

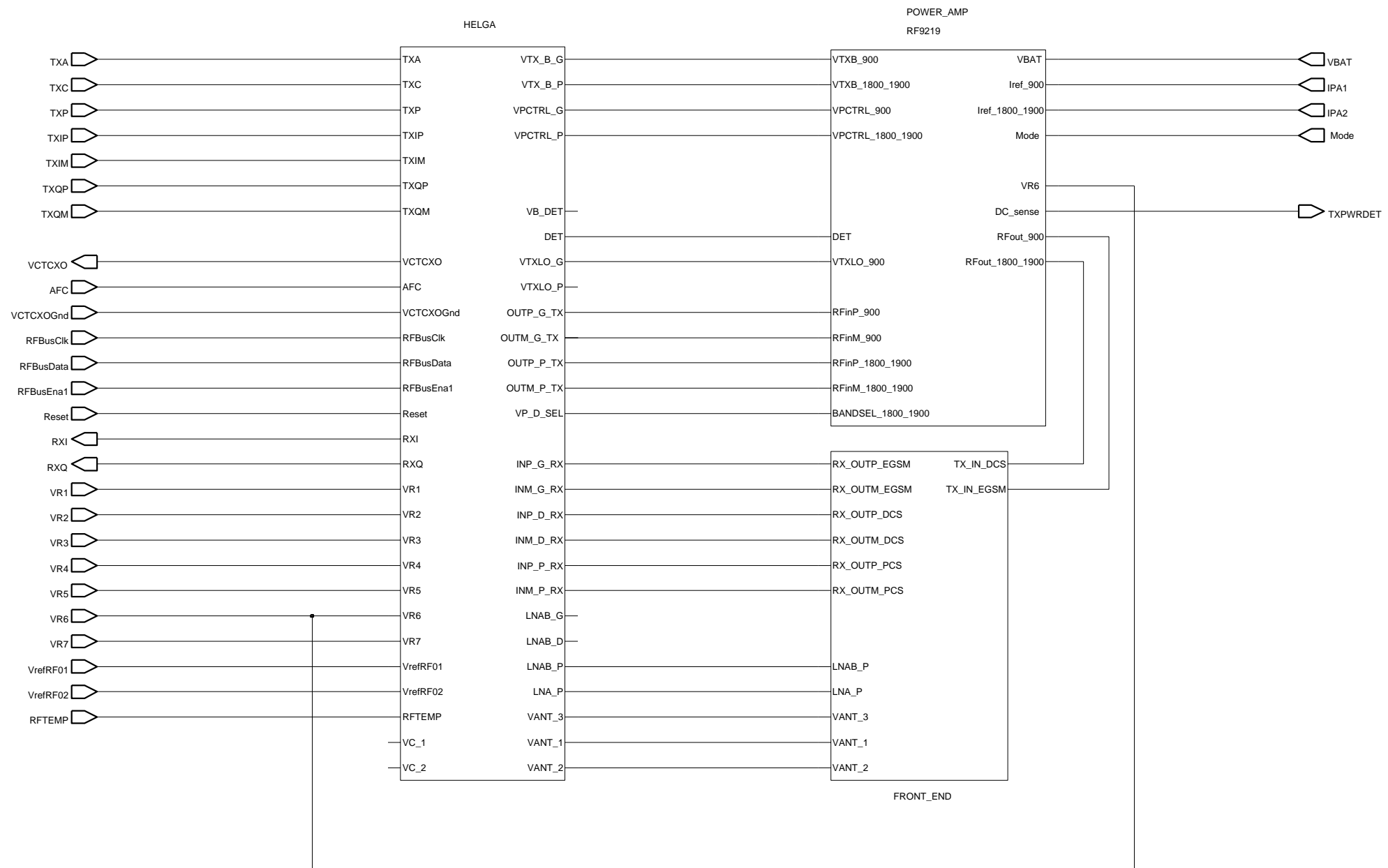

RF grounds (ed. 0 ver.2)

RF GLOBAL GND HOLES

SYSTEM GLOBAL GND HOLES

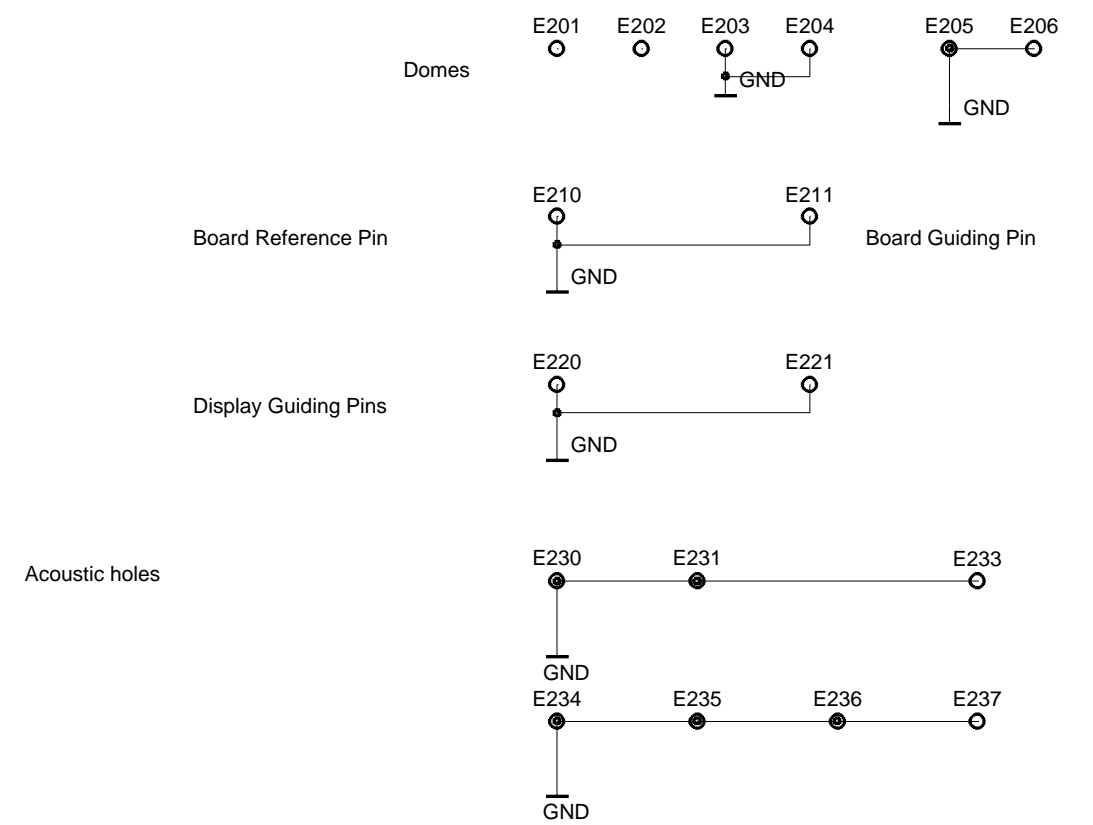

HELGO ASIC (ver. 0.0 ed.2)

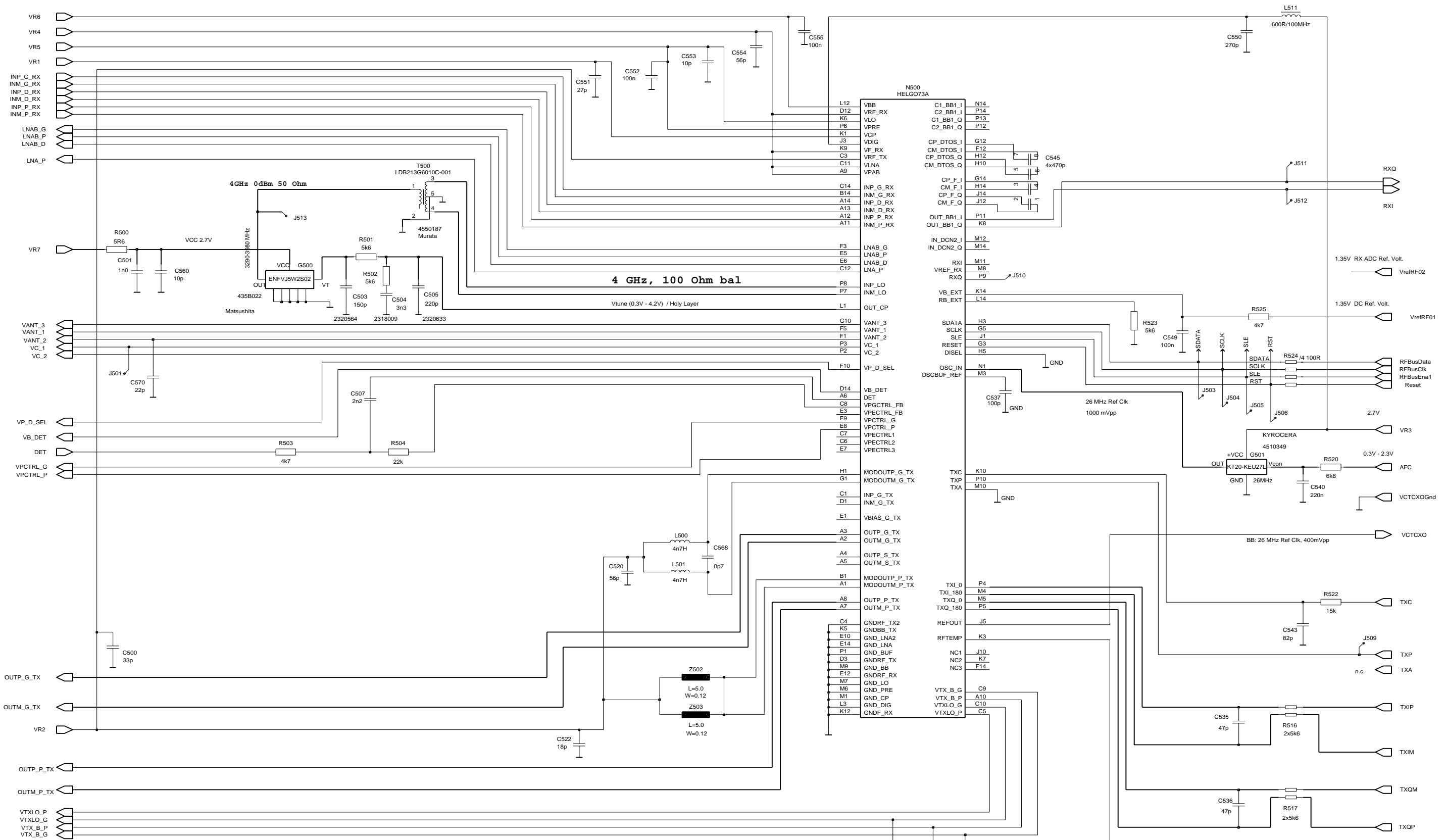

Last references:
 C572
 R539
 L511
 T501
 Tracking filter: R534, R535

Power amplifier and detection (ver.2.0 ed 2)

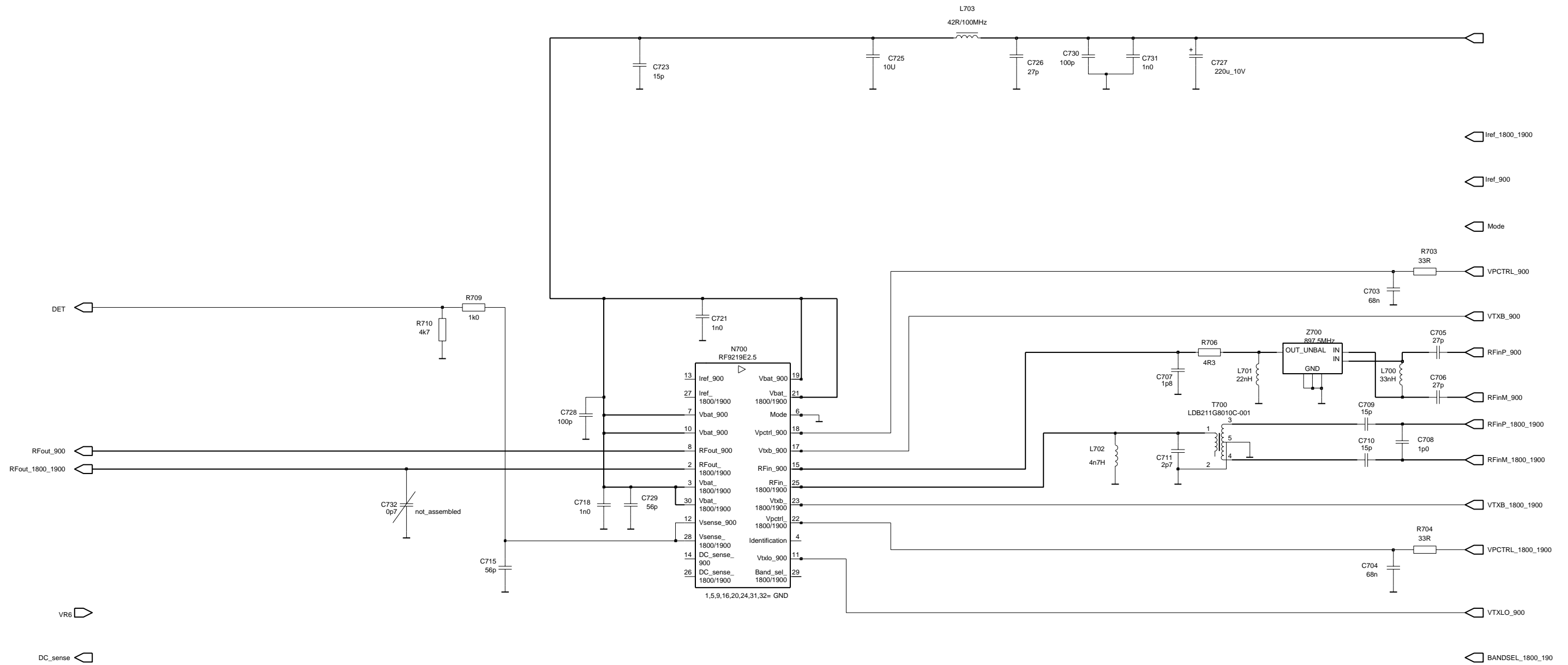

Last references:

C732

R720

L704

RX front end and antenna swit (Ver. 2.0 ed. 2)

LNA_P

RX_OUTM_PCS

RX_OUTP_PCS

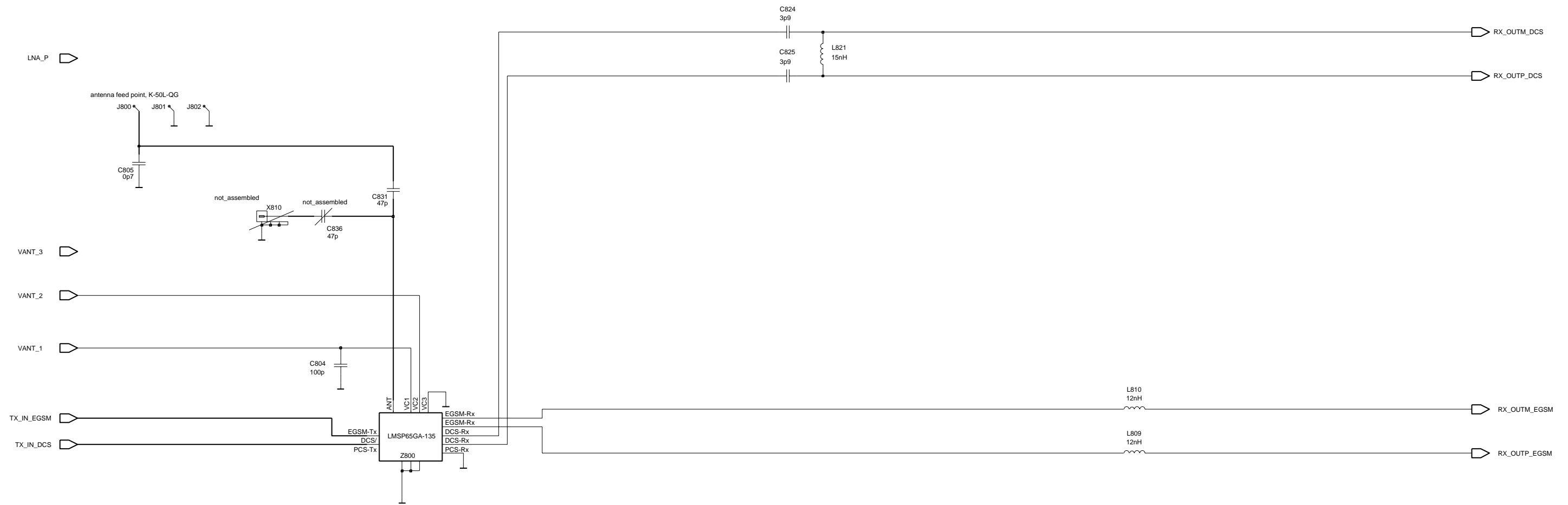

Last references:

- C835
- R806
- L825
- Z806

SIM reader (ver. 0.0 ed. 2)

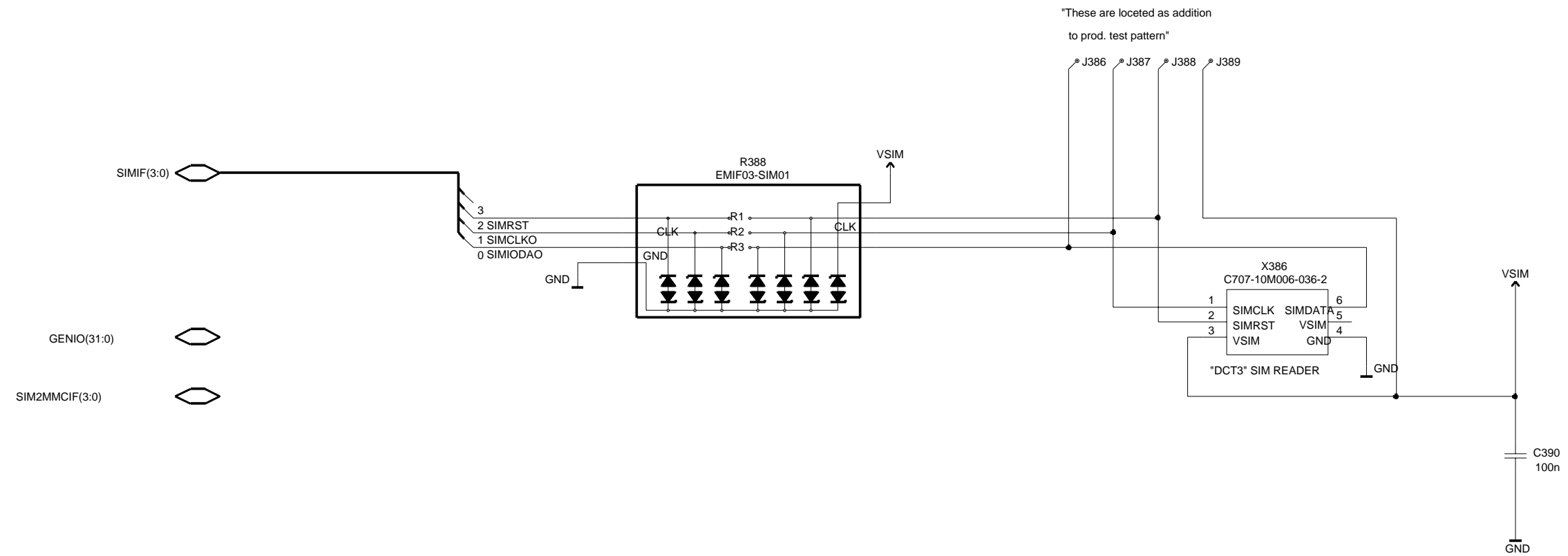

Application Engine Interface v. 1.3 ed.2

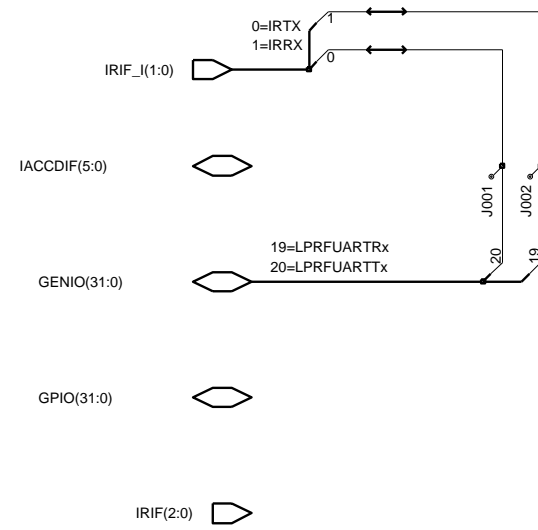

FM radio unit (v.1.3 ed.153)

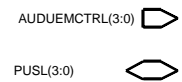
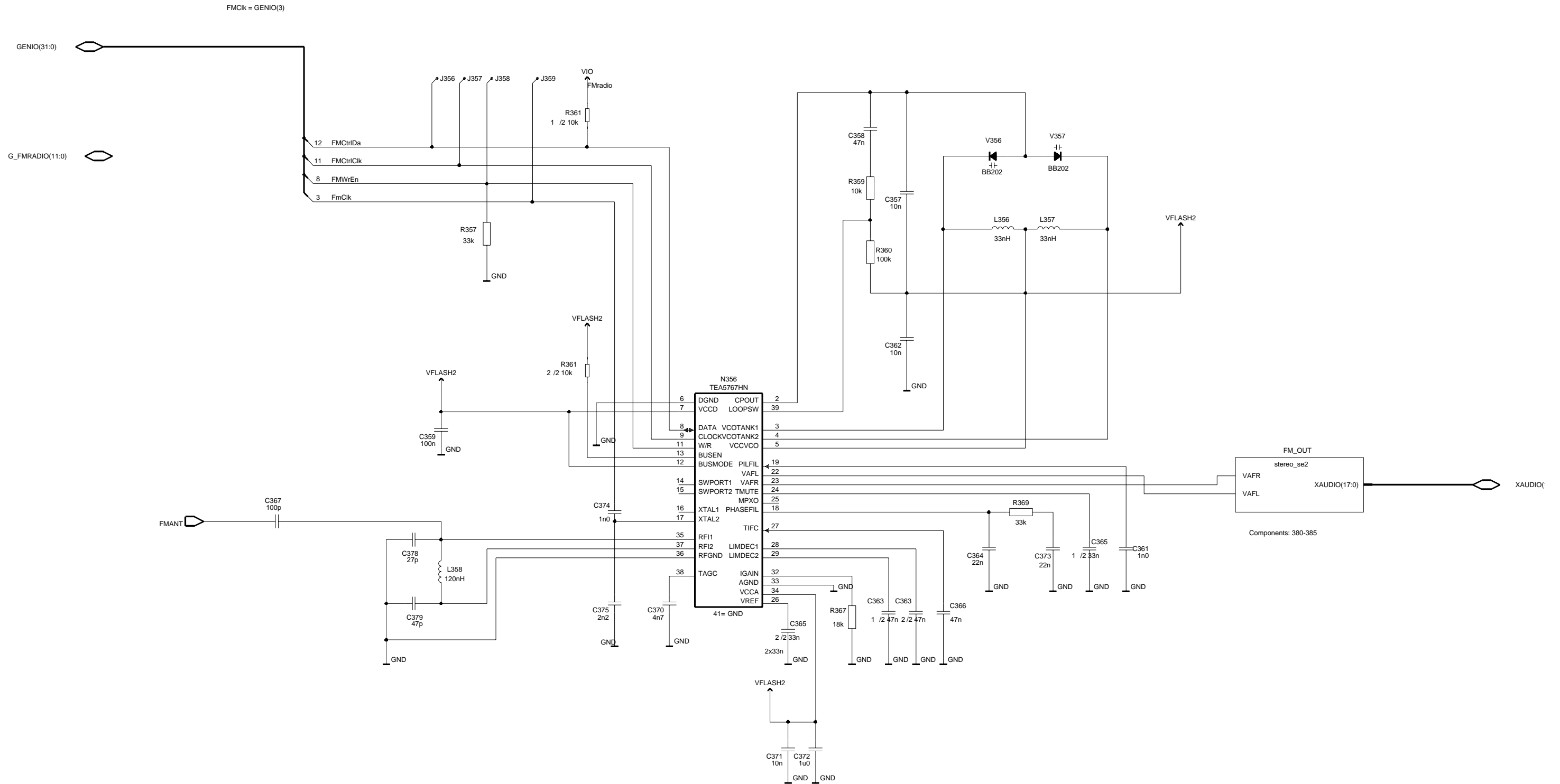

Notice:
 C374 (1n0) and C375 (2n2) are configured for 32kHz reference clock
 If reference clock is 6.5MHz, use C374 (3p9) and C375 (10p)

FM radio unit 2 (v. 0.0 ed.118)

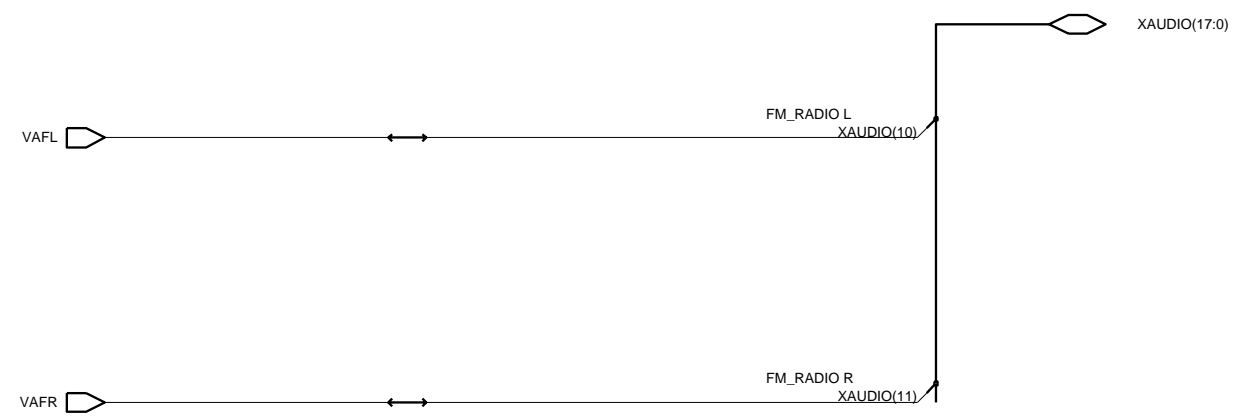

UPP 8M (v.2.0 ed.102)

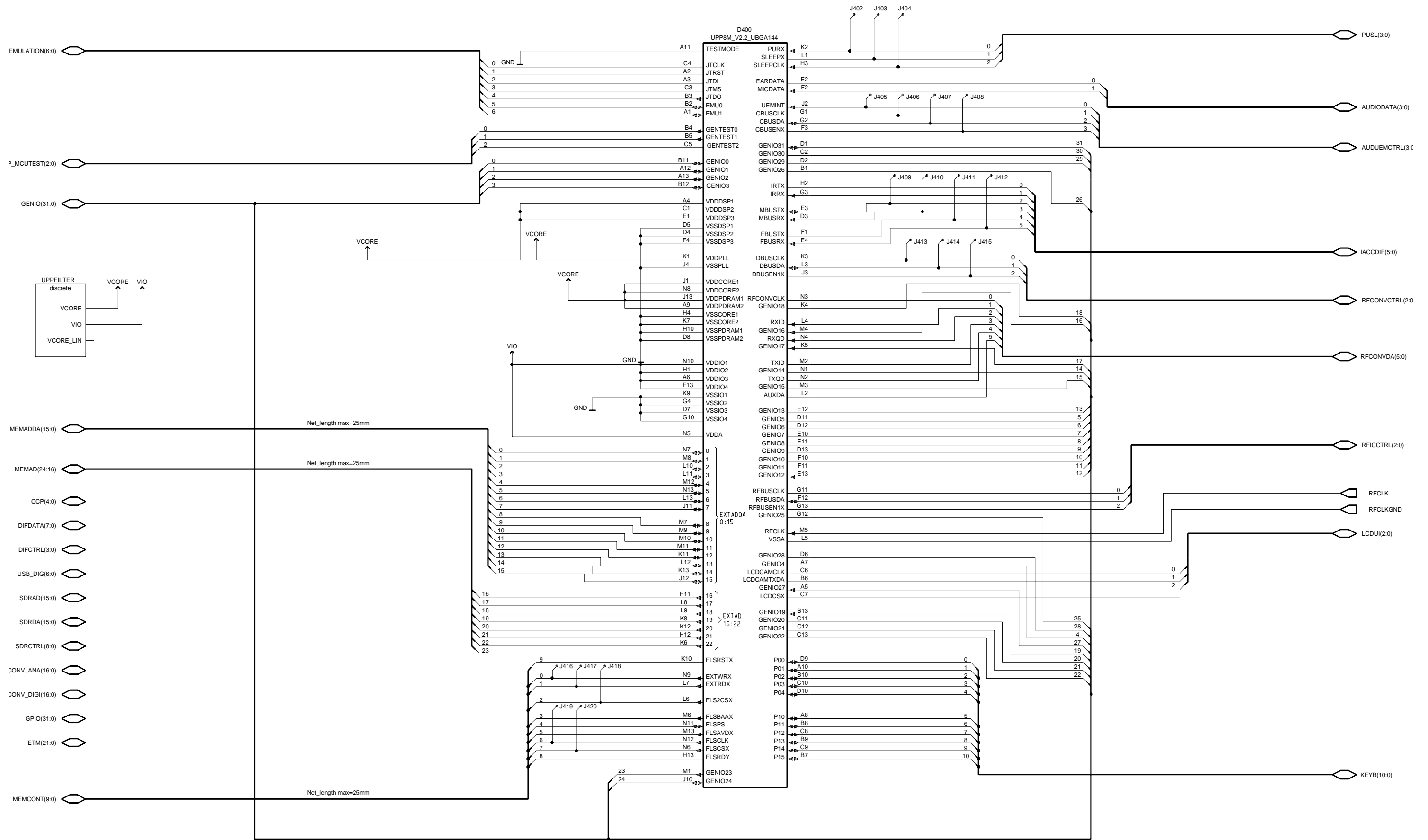

Discrete power management (ver. 1.3 ed. 115)

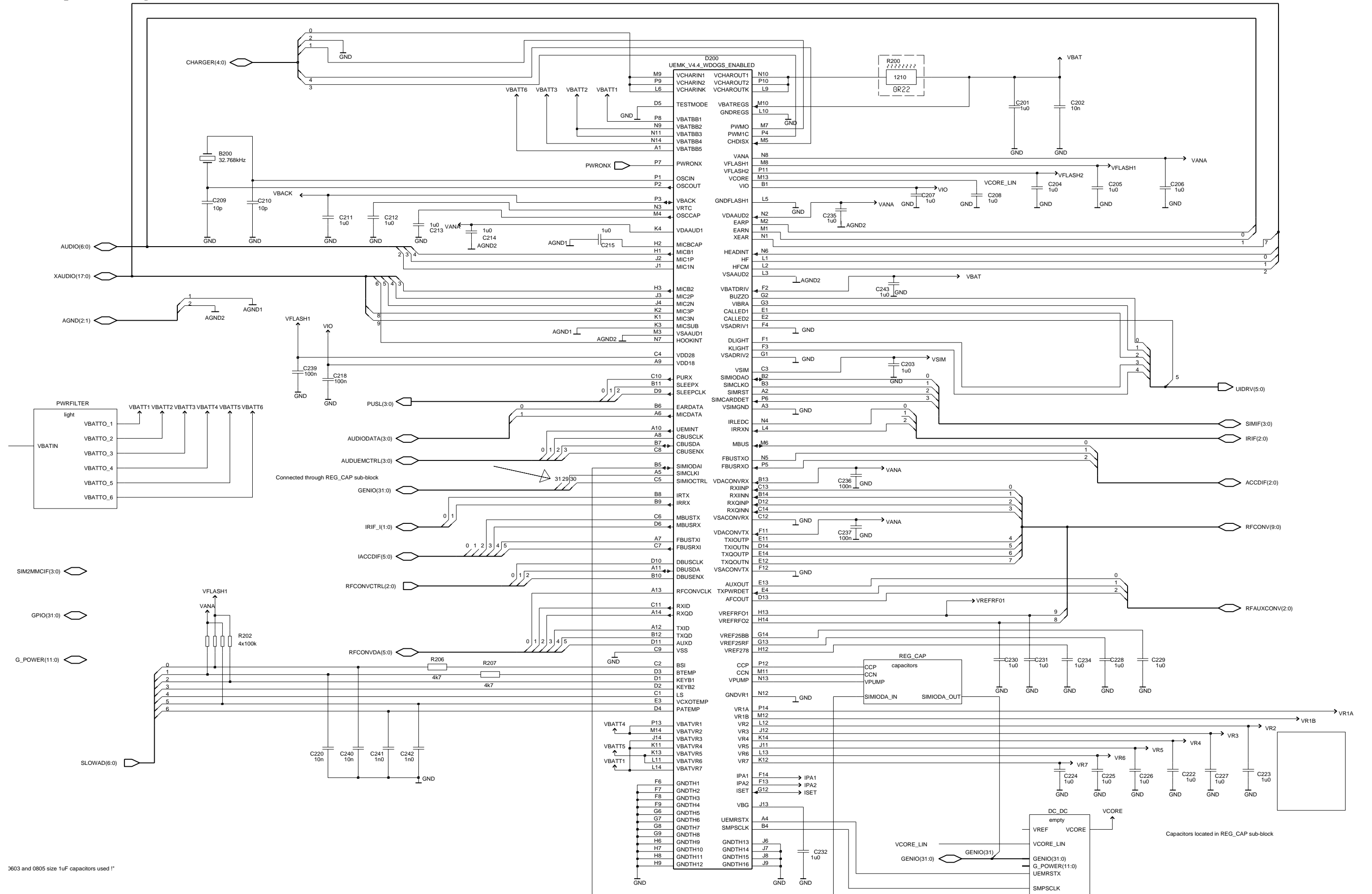

0603 and 0805 size 1uF capacitors used !*

Light filtering (ver. 2.0 ed. 28)

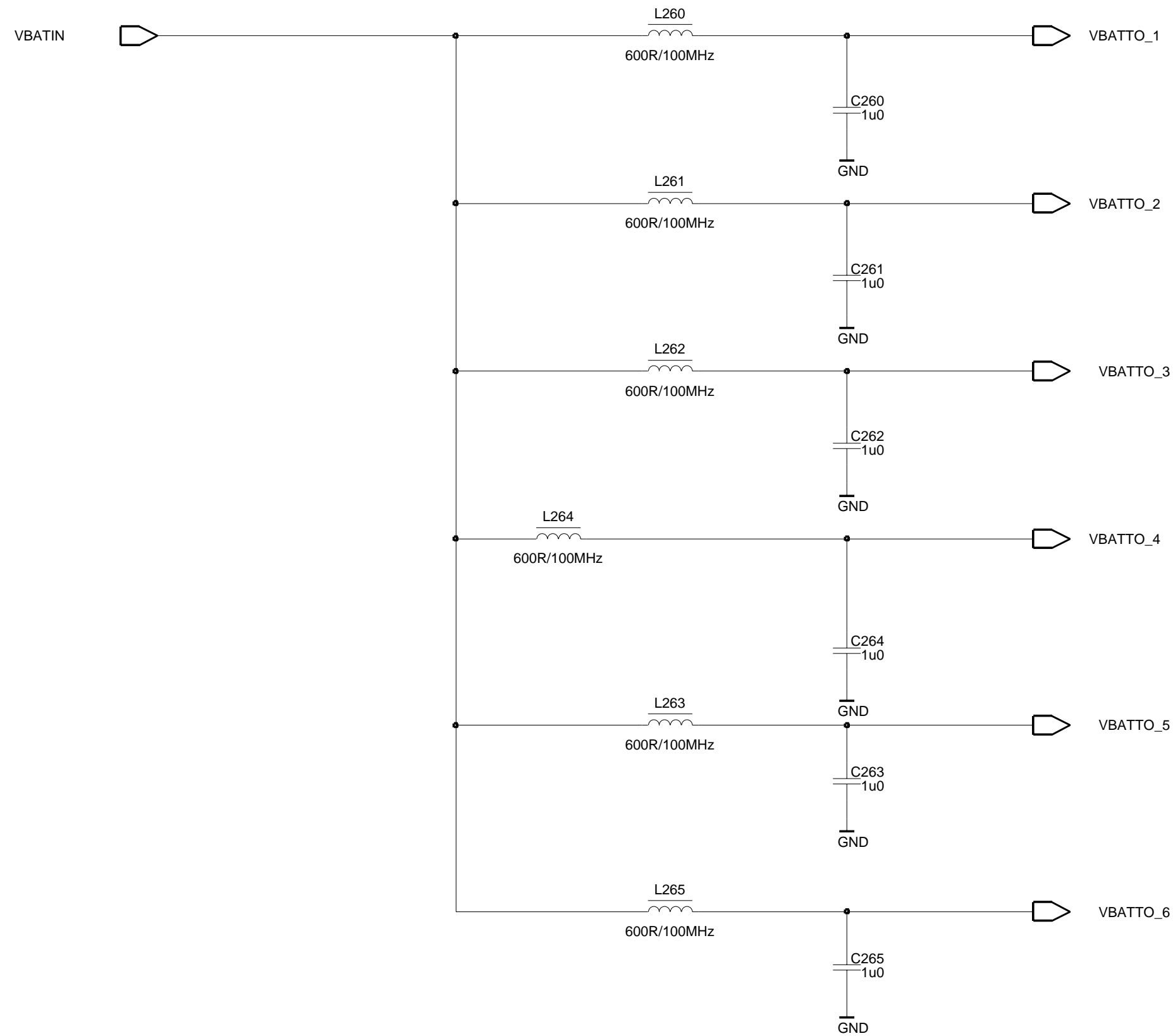

Old power discrete (ver. 0.0 ed. 8)

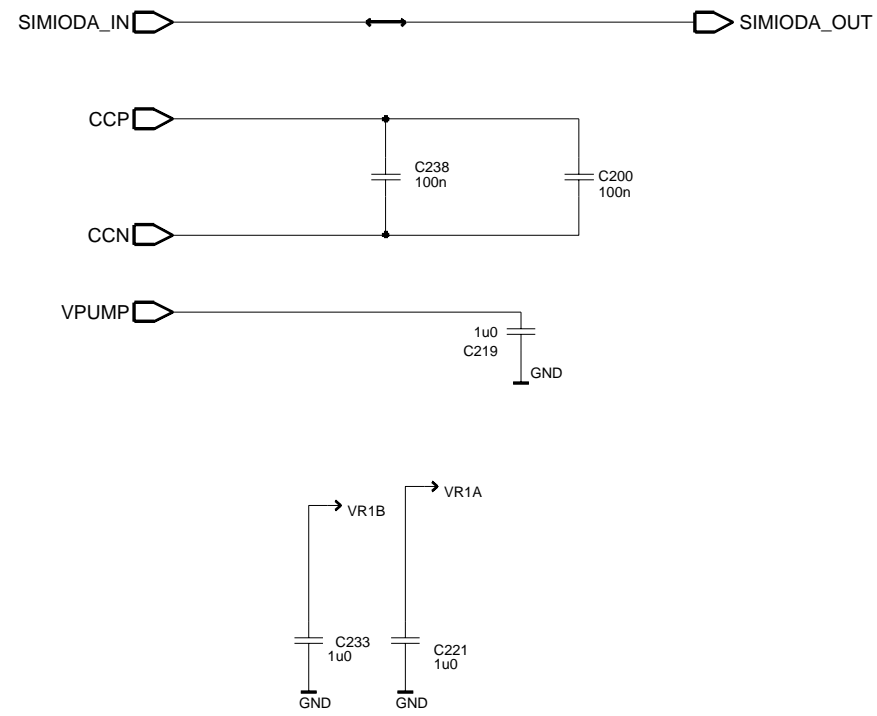

GSM RF-Baseband interface (ver. 1.3 ed.39)

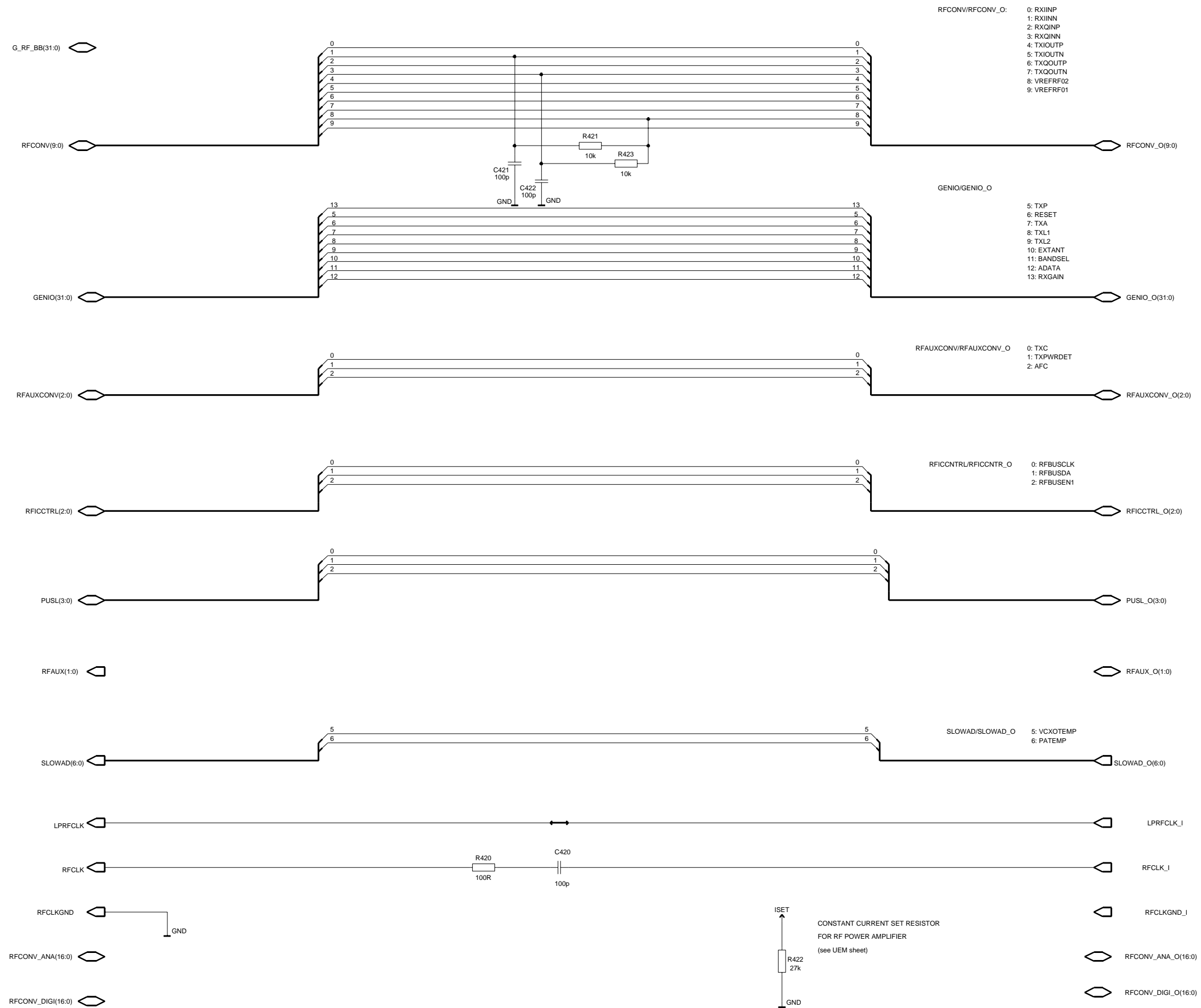

IF IPA1 AND IPA2 ARE USED BY RF THE TOLERANCE HAS TO BE 1% (0402, 1430873)

Flash memory (ver. 2.0 ed.56)

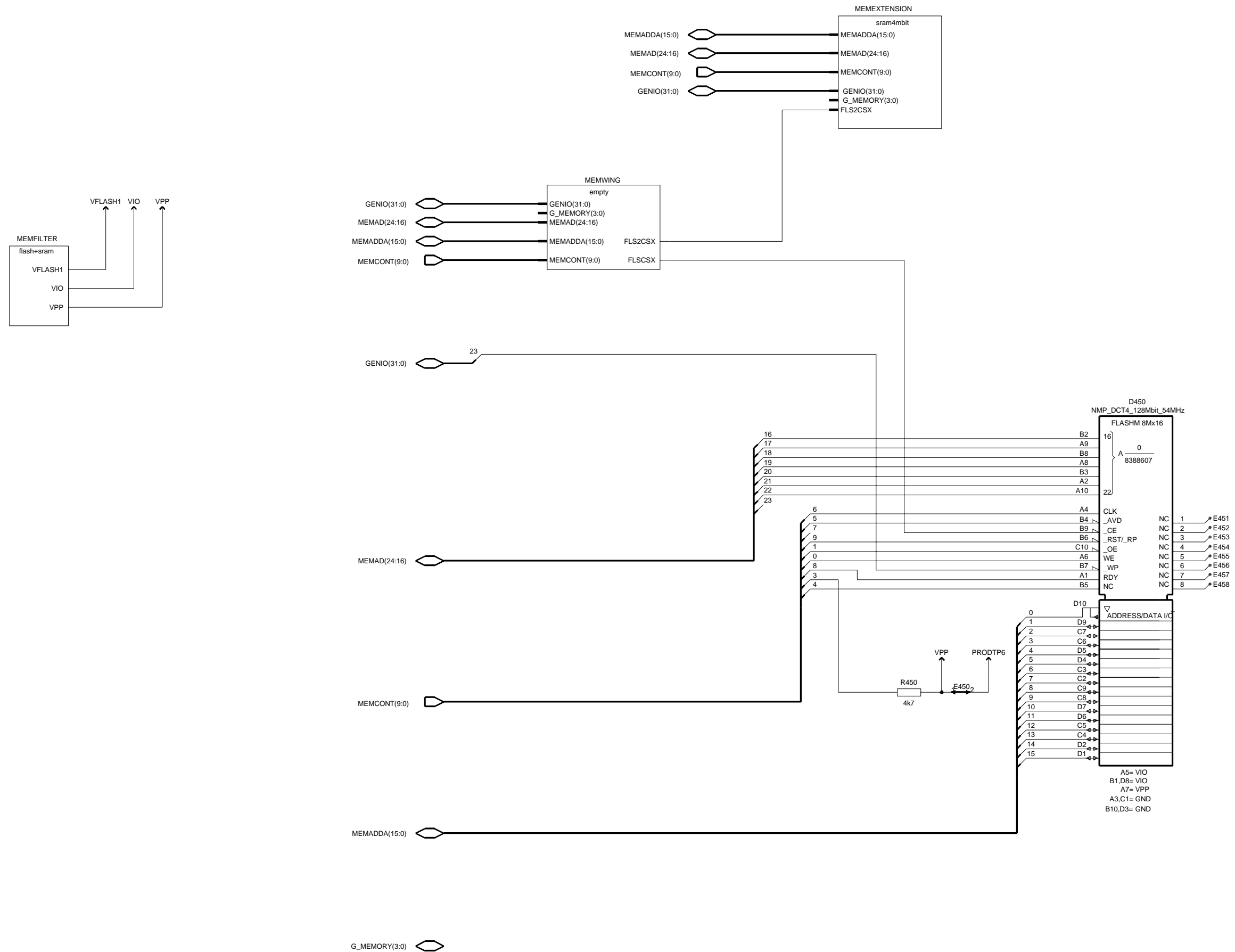

4Mbit SRAM (ver. 2.0 ed.31)

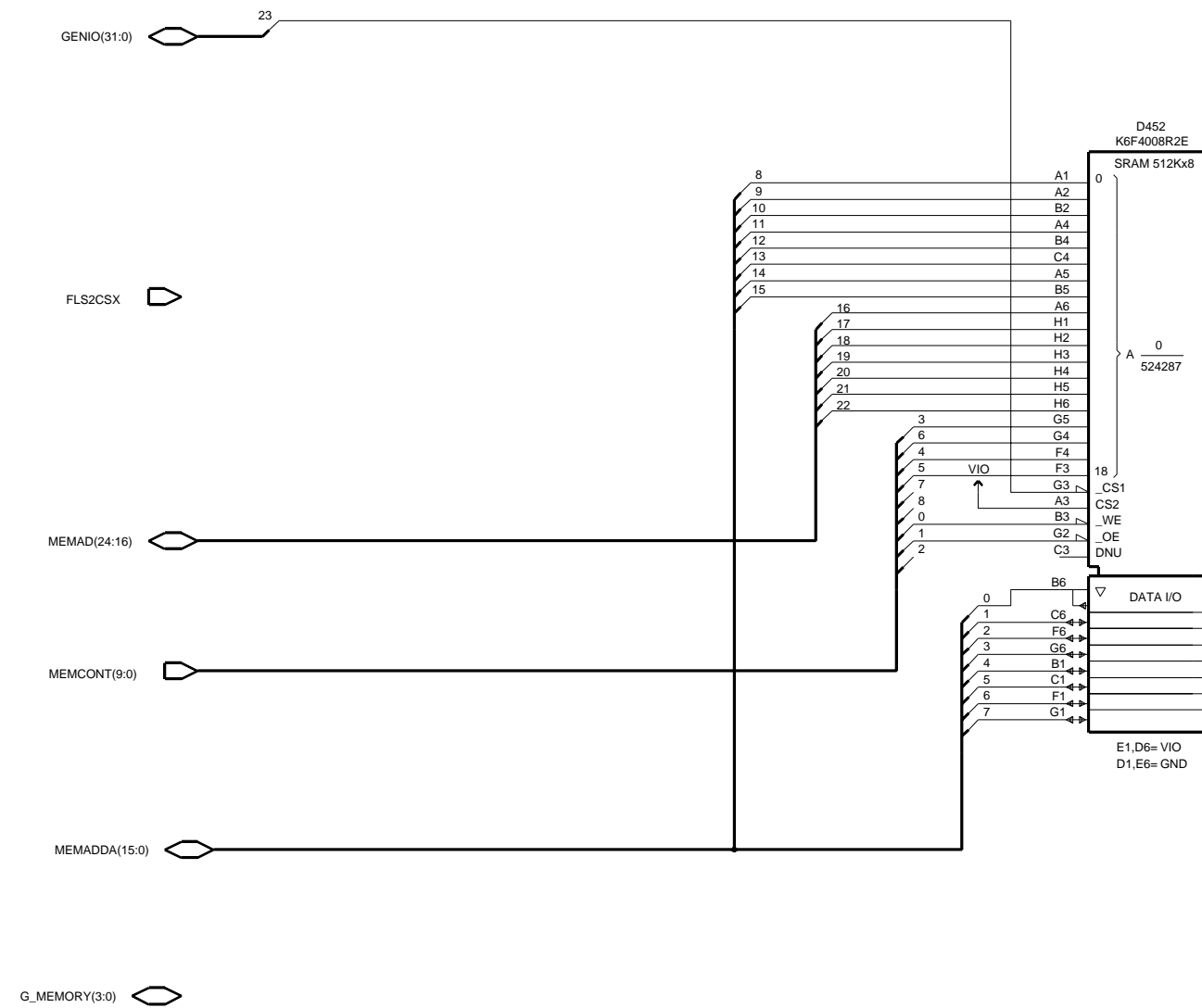

Decoupling capacitors for Flash and SRAMs (v.2.0 ed.6)

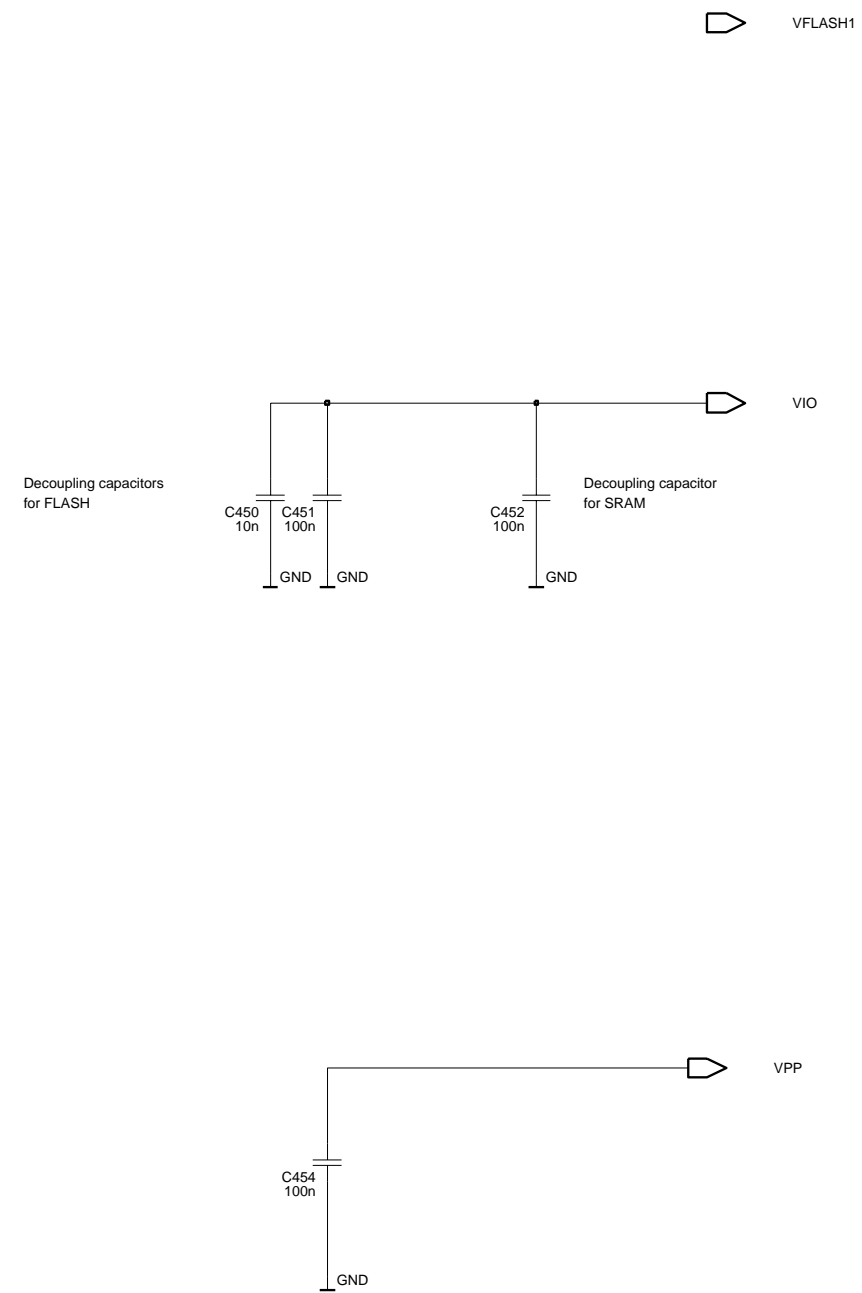

Parts Placement EM11_10a_top

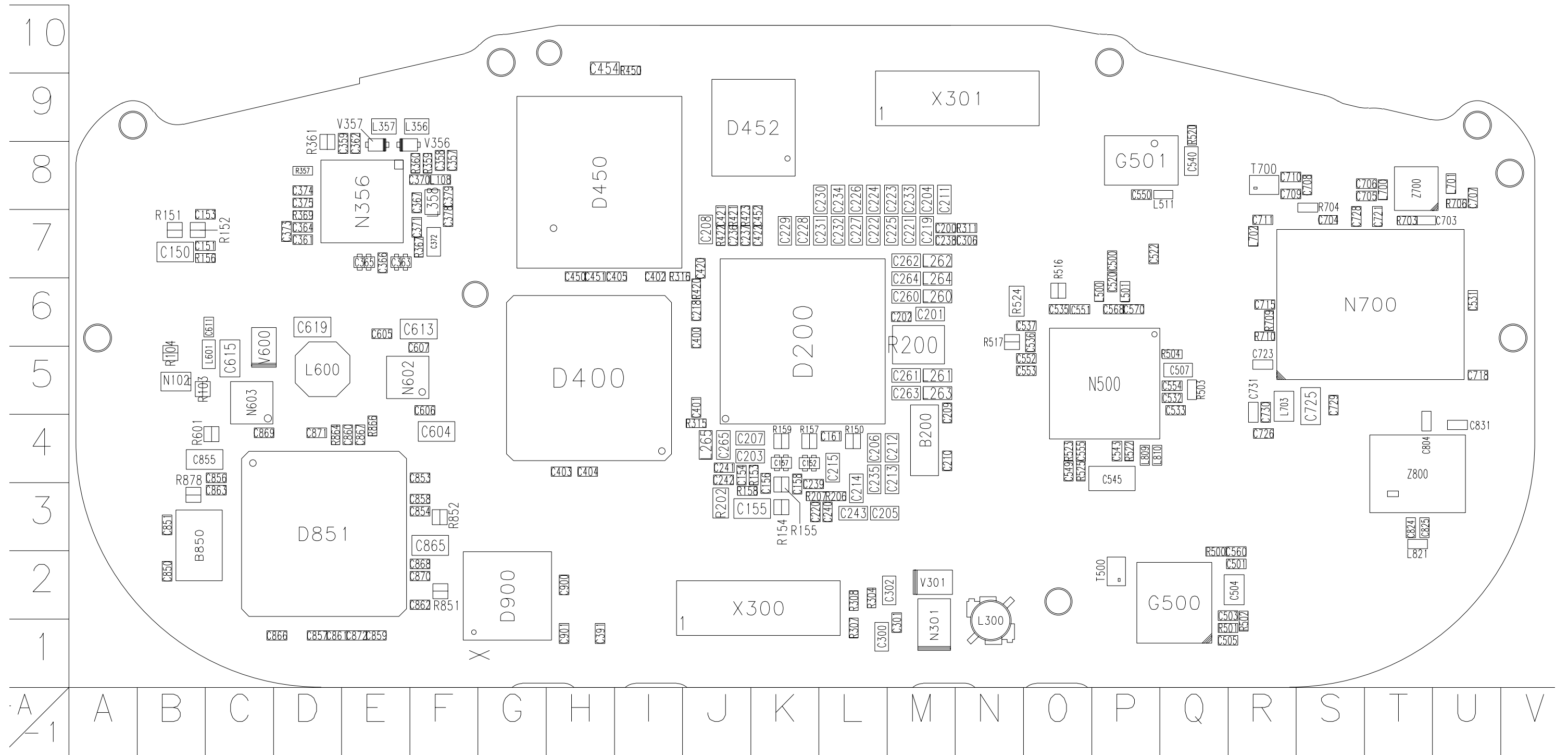

Test Points

Parts Placement EM11_10a, bottom

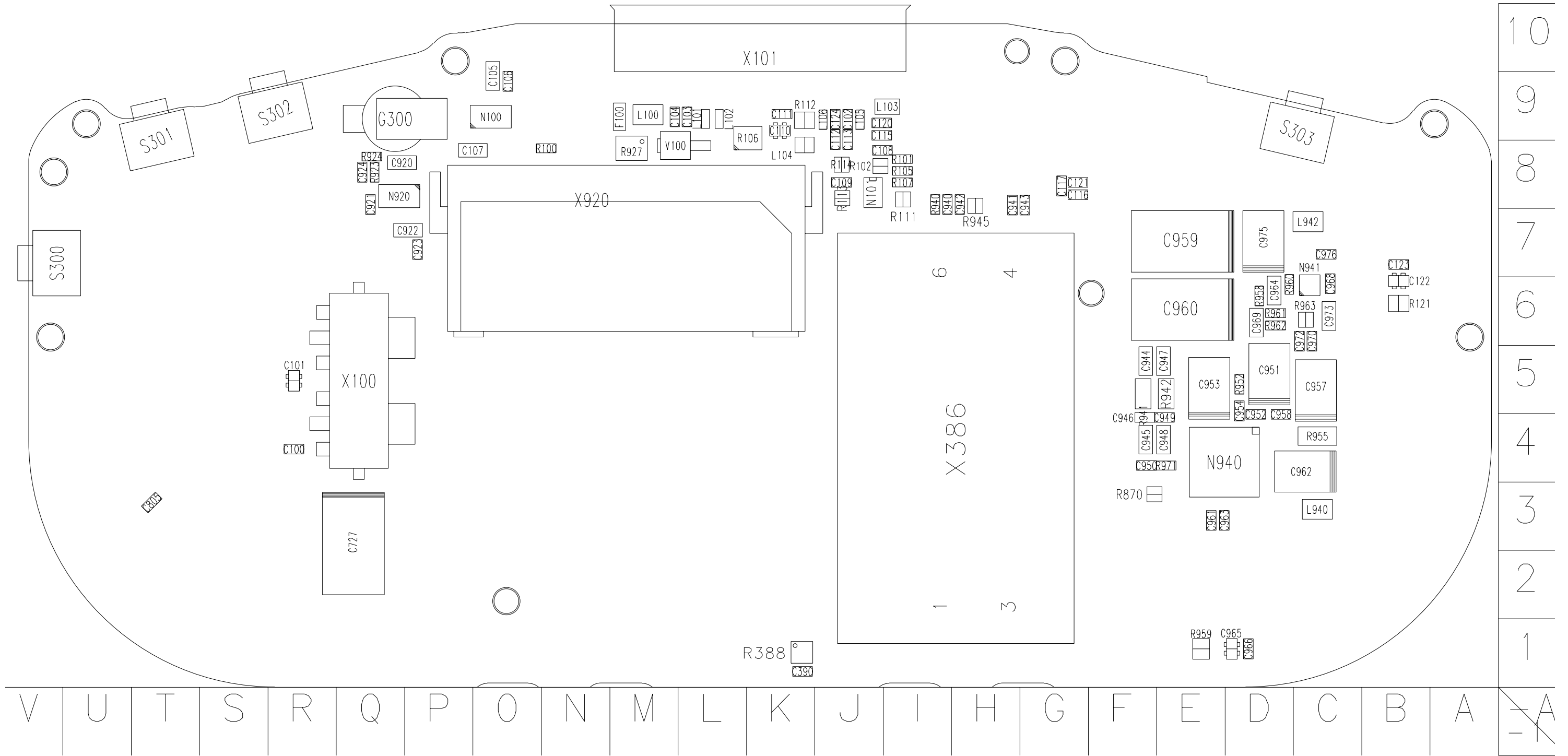

Test Points EM11_10, top

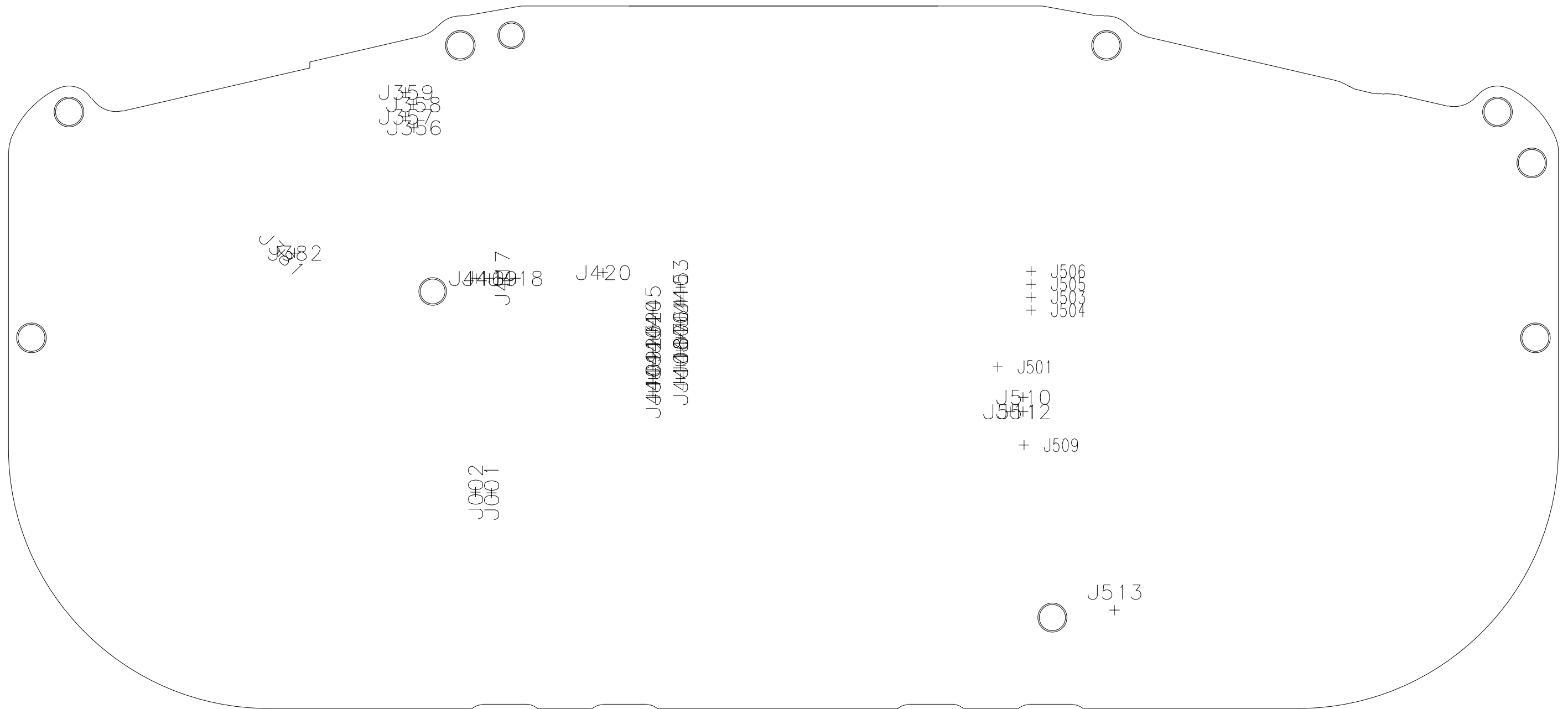

Test Points EM11_10, bottom

